

Proportional-Integral Controllers for Minimum-Phase Nonaffine-in-control Systems

Justin Teo, Jonathan P. How, and Eugene Lavretsky

Abstract—We show that stabilizing tracking proportional-integral (PI) controllers can be constructed for minimum-phase nonaffine-in-control systems. The constructed PI controller is an equivalent realization of an approximate dynamic inversion controller. This equivalence holds only for the time response when applied to the unperturbed system. Even when restricted to unperturbed minimum-phase linear time invariant systems, their closed loop robustness properties differ. This shows that in general, properties that do not define the equivalence relation for systems/controllers are not preserved under such equivalence transformations.

Index Terms—proportional-integral control, nonaffine-in-control systems, nonlinear systems, feedback linearization.

I. INTRODUCTION

The proportional-integral (PI) controller is perhaps one of the most utilized and important constructions available for control of a large class of systems. In addition to its classical applications to linear time invariant (LTI) systems, justifications for the use of PI controllers on *nonlinear* systems have been furnished in [1]–[3], to name a few that are most relevant to the present note. In [2], single-input-single-output (SISO) *affine-in-control* nonlinear systems are considered. It was shown that when the system is minimum-phase, an *output-feedback* PI controller with a high-gain observer (termed *universal integral controller* in [2]) can achieve asymptotic tracking of a sufficiently smooth reference signal that approaches a constant limit. For multi-input-multi-output (MIMO) *nonaffine-in-control* systems, [1] showed that if the open-loop system is exponentially stable, a stabilizing tracking PI controller can be constructed.

In this note, we will show that for SISO minimum-phase *nonaffine-in-control* systems, a stabilizing tracking PI controller can be constructed. The extension to a (restricted) class of MIMO minimum-phase nonaffine-in-control systems is presented in [4], [5]. The results of this note complement [1], [2] by

- 1) extending the applicability of PI controllers to unstable (minimum-phase) *nonaffine-in-control* systems,
- 2) showing that the constructed PI controller can be interpreted as an *exact* realization of an *approximate* feedback linearizing controller [6], and
- 3) showing that bounded tracking is achieved for reference signals not necessarily approaching a constant limit.

Some practical examples of nonaffine-in-control systems include the continuous stirred tank reactor [7], switched reluctance motors [8], and some aircraft models [9].

The PI controller is derived from an *approximate dynamic inversion* (ADI) controller proposed in [6] (see also [5]). The ADI control law, as the name suggests, is an approximation of exact dynamic inversion or feedback linearization [10]. Given a minimum-phase *nonaffine-in-control* system, the ADI control law drives it towards a chosen stable reference model. The control signal was defined as a solution of “fast” dynamics, and Tikhonov’s Theorem [11, Theorem 11.2,

pp. 439 – 440] from singular perturbation theory was invoked to show that the control signal approaches the exact dynamic inversion solution, and the system state approaches and maintains within an arbitrarily small neighborhood of the reference model state, when the controller dynamics are made sufficiently fast. In contrast to the ADI control law, the *derived* PI controller is largely independent of the system’s nonlinearities, rendering it relatively insensitive to parametric uncertainties. However, when the controller have fast dynamics as required of the ADI method, the resulting PI controller is a high-gain controller with associated robustness problems [12].

A set of controllers can be considered *equivalent* when they all satisfy some common properties. In [13, Section 5.4], two systems are defined to be equivalent if and only if, to every initial condition in either system, there corresponds a compatible initial condition in the other system for which they produce the same output time response for the same excitation. It is common practice to transform a system into an equivalent one for analysis/design, and then transform it into another equivalent form for implementation due to convenience and/or necessity to maintain tractability. In the second part of this note, we will show that robustness properties may not be preserved under such equivalence transformations. In particular, the equivalence between the ADI and PI controllers holds only for the time response when applied to the *exact* system. Even when restricted to *unperturbed* minimum-phase LTI systems, robustness properties are not preserved. These results mirror those of [14], where an equivalence class of controllers satisfying the same optimality criterion is derived from a nominal optimal controller, and performance is not preserved for all controllers from the same equivalence class under some perturbations. Also, [15] has a similar notion of equivalent feedback, although robustness properties among controllers in the same equivalence class were not investigated. The main message of the second part is thus that extra caution is due when performing such transformations, and properties that do not define the equivalence class (e.g. robustness properties of the closed-loop system for the class of stabilizing controllers that achieve the same time response) for a system cannot be assumed to hold under such equivalence transformations.

II. EQUIVALENCE BETWEEN APPROXIMATE DYNAMIC INVERSION AND PI CONTROL

In this section, we show that every ADI controller [6] admits an equivalent PI controller realization. This means that a stabilizing tracking PI controller exists for SISO *minimum-phase* nonaffine-in-control systems with a constant well-defined relative degree, for sufficiently smooth bounded reference signals not necessarily approaching a constant limit. The extension to a restricted class of MIMO systems is straightforward [4], [5]. First, we present the ADI method and its main result in [6] (see also [5] for differences with [6]), with a minor generalization.

A. Approximate Dynamic Inversion for Nonaffine-in-control SISO Systems

Consider an n -th order SISO *nonaffine-in-control* system of (constant and well-defined) relative degree ρ , expressed in normal form

$$\begin{aligned}\xi^{(\rho)} &= f(x, z, u), & x(0) &= x_0, \\ \dot{z} &= g(x, z, u), & z(0) &= z_0,\end{aligned}\quad (1)$$

defined for all $(x, z, u) \in D_x \times D_z \times D_u$ with $D_x \subset \mathbb{R}^\rho$, $D_z \subset \mathbb{R}^{n-\rho}$ and $D_u \subset \mathbb{R}$ being domains containing the origins. The (partial) state x is defined as $x = [\xi, \dot{\xi}, \xi^{(2)}, \dots, \xi^{(\rho-1)}]^T$, and $\xi^{(q)}$ denotes the q -th time derivative of ξ . The state vector of the system is $[x^T, z^T]^T$, u is the control input, and $f: D_x \times D_z \times D_u \rightarrow \mathbb{R}$, $g: D_x \times$

Manuscript received June 4, 2009; revised October 14, 2009. J. Teo gratefully acknowledges the support of DSO National Laboratories, Singapore. Research funded in part by AFOSR grant FA9550-08-1-0086.

J. Teo and J. P. How are with the Department of Aeronautics & Astronautics, Massachusetts Institute of Technology, Cambridge, MA 02139, USA. (e-mail: csteo@mit.edu; jhow@mit.edu)

E. Lavretsky is with Boeing Research & Technology, The Boeing Company, Huntington Beach, CA 92647, USA. (e-mail: eugene.lavretsky@boeing.com) Digital Object Identifier 10.1109/TAC.2010.2045693

$D_x \times D_u \rightarrow \mathbb{R}^{n-\rho}$ are continuously differentiable functions of their arguments. To ensure that its relative degree is constant and well-defined, assume that $\frac{\partial f}{\partial u}$ is bounded away from zero for all $(x, z, u) \in D_x \times D_z \times D_u$. That is, there exists $b_0 > 0$ such that $|\frac{\partial f}{\partial u}| \geq b_0$ for all $(x, z, u) \in D_x \times D_z \times D_u$. This implies that $\text{sgn}(\frac{\partial f}{\partial u}) \in \{-1, +1\}$ is a constant, and that $\psi: u \mapsto f(x, z, u)$ is a bijection for every fixed $(x, z) \in D_x \times D_z$. Note that f need not be explicitly invertible with respect to u .

The problem is to design a controller so that x tracks the state of a chosen ρ -th order *stable* linear reference model

$$\xi_r^{(\rho)} + a_{r(\rho-1)}\xi_r^{(\rho-1)} + \dots + a_{r1}\dot{\xi}_r + a_{r0}\xi_r = b_r r, \quad (2)$$

where $x_r = [\xi_r, \dot{\xi}_r, \xi_r^{(2)}, \dots, \xi_r^{(\rho-1)}]^T \in \mathbb{R}^\rho$ is its state, $x_r(0) = x_{r0}$ is some chosen initial state, and r is a continuously differentiable reference input signal with bounded time derivative \dot{r} . Stability of the reference model requires that all roots of the characteristic equation $s^\rho + a_{r(\rho-1)}s^{\rho-1} + \dots + a_{r1}s + a_{r0} = 0$ lie in the open left half complex plane, denoted by \mathbb{C}_- .

Define the tracking error $\xi_e = \xi - \xi_r$ and error vector $e = x - x_r = [\xi_e, \dot{\xi}_e, \xi_e^{(2)}, \dots, \xi_e^{(\rho-1)}]^T \in \mathbb{R}^\rho$, and choose the desired *stable* error dynamics

$$\xi_e^{(\rho)} + a_{e(\rho-1)}\xi_e^{(\rho-1)} + \dots + a_{e1}\dot{\xi}_e + a_{e0}\xi_e = 0, \quad (3)$$

with initial condition defined by $e(0) = e_0 = x_0 - x_{r0}$. Similarly, stability of the desired error dynamics requires that all roots of $s^\rho + a_{e(\rho-1)}s^{\rho-1} + \dots + a_{e1}s + a_{e0} = 0$ lie in \mathbb{C}_- . Observe that in [6], a_{ei} was set equal to a_{ri} for $i \in \{0, 1, \dots, \rho-1\}$. This is a minor extension of [6] that allows the error dynamics to be specified independently of the reference model dynamics.

For notational convenience in the sequel, define

$$\begin{aligned} a_r &= [a_{r0}, a_{r1}, \dots, a_{r(\rho-1)}]^T, & \alpha &= \text{sgn}\left(\frac{\partial f}{\partial u}\right). \\ a_e &= [a_{e0}, a_{e1}, \dots, a_{e(\rho-1)}]^T, \end{aligned}$$

As observed above, $\alpha \in \{-1, +1\}$ is a constant for all $(x, z, u) \in D_x \times D_z \times D_u$. The open-loop (time-varying) error dynamics are then given by the system

$$\begin{aligned} \xi_e^{(\rho)} &= f(e + x_r(t), z, u) + a_r^T x_r(t) - b_r r(t), & e(0) &= e_0, \\ \dot{z} &= g(e + x_r(t), z, u), & z(0) &= z_0. \end{aligned} \quad (4)$$

The ideal dynamic inversion control is found by solving

$$f(e + x_r(t), z, u) + a_r^T x_r(t) - b_r r(t) = -a_e^T e \quad (5)$$

for u , resulting in the exponentially stable closed-loop tracking error dynamics (3). Since (5) cannot (in general) be solved explicitly for u , the ADI controller [6]

$$\epsilon \dot{u} = -\alpha \tilde{f}(t, e, z, u), \quad u(0) = u_0, \quad (6)$$

where

$$\tilde{f}(t, e, z, u) = f(e + x_r(t), z, u) + a_r^T x_r(t) - b_r r(t) + a_e^T e,$$

approximates the exact dynamic inversion solution via fast dynamics.

Let $u = h(t, e, z)$ be an isolated root of $\tilde{f}(t, e, z, u) = 0$. In accordance with the theory of singular perturbations [11, Chapter 11], the reduced system for (4), (6), is

$$\begin{aligned} \xi_e^{(\rho)} &= -a_e^T e, & e(0) &= e_0, \\ \dot{z} &= g(e + x_r(t), z, h(t, e, z)), & z(0) &= z_0. \end{aligned}$$

With $v = u - h(t, e, z)$ and $\tau = t/\epsilon$, the boundary layer system is

$$\frac{dv}{d\tau} = -\alpha \tilde{f}(t, e, z, v + h(t, e, z)). \quad (7)$$

The main result of [6], adapted for the above extension and presented in [5, Theorem 4], is the following.

Theorem 1 (Hovakimyan et al. [6, Theorem 2], [5, Theorem 4]): Consider the system (4) and (6), and let $u = h(t, e, z)$ be an isolated root of $\tilde{f}(t, e, z, u) = 0$. Assume that the following conditions hold for all

$$(t, e, z, u - h(t, e, z), \epsilon) \in [0, \infty) \times D_{e,z} \times D_v \times [0, \epsilon_0],$$

for some domains $D_{e,z} \subset \mathbb{R}^n$ and $D_v \subset \mathbb{R}$ which contain their respective origins:

- 1) On any compact subset of $D_{e,z} \times D_v$, the functions f, g , their first partial derivatives with respect to (x, z, u) , and $r(t), \dot{r}(t)$ are continuous and bounded, $h(t, e, z)$ and $\frac{\partial f}{\partial u}(x, z, u)$ have bounded first partial derivatives with respect to their arguments, and $\frac{\partial f}{\partial x}, \frac{\partial f}{\partial z}, \frac{\partial g}{\partial x}, \frac{\partial g}{\partial z}$ as functions of $(e + x_r(t), z, h(t, e, z))$, are Lipschitz in e and z uniformly in t .
- 2) The origin is an exponentially stable equilibrium of the system

$$\dot{z} = g(x_r(t), z, h(t, 0, z)).$$

The map $(e, z) \mapsto g(e + x_r(t), z, h(t, e, z))$ is continuously differentiable and Lipschitz in (e, z) uniformly in t .

- 3) $(t, e, z) \mapsto \left| \frac{\partial f}{\partial u}(e + x_r(t), z, h(t, e, z)) \right|$ is bounded from below by some positive number for all $(t, e, z) \in [0, \infty) \times D_{e,z}$.

Then the origin of (7) is exponentially stable. Let $R_v \subset D_v$ be the region of attraction of the autonomous system

$$\frac{dv}{d\tau} = -\alpha \tilde{f}(0, e_0, z_0, v + h(0, e_0, z_0)),$$

and Ω_v be a compact subset of R_v . Then, for each compact subset $\Omega_{e,z} \subset D_{e,z}$, there exists positive constants ϵ^* and T such that for all $t > 0$, $(e_0, z_0) \in \Omega_{e,z}$, $u_0 - h(0, e_0, z_0) \in \Omega_v$, and $\epsilon \in (0, \epsilon^*)$, the system (1), (2), (6) has a unique solution $x(t, \epsilon), z(t, \epsilon), x_r(t), u(t, \epsilon)$ on $[0, \infty)$, and

$$x(t, \epsilon) - x_r(t) = O(\epsilon)$$

holds uniformly for all $t \in [T, \infty)$.

Proof: See [5], [6]. ■

Observe that bounded tracking is achieved even when the reference signal r does not approach a constant limit. An extension of [6] applicable to a larger class of MIMO nonaffine-in-control systems is presented in [16], where the *instantaneous* control signal is obtained as the minimizer of the discrepancy between the control signal and the exact dynamic inversion solution in a least squares sense.

B. PI Controller for Nonaffine-in-control SISO Systems

The following is the key result which shows that a stabilizing tracking PI controller exists for system (1).

Theorem 2: For every approximate dynamic inversion controller (6), there exists a *linear* proportional-integral controller realization

$$u(t) = -\frac{\alpha}{\epsilon} \left(\xi_e^{(\rho-1)}(t) + a_e^T \int_0^t e(\gamma) d\gamma - \tilde{u}_0 \right), \quad (8)$$

where $\tilde{u}_0 = \xi_e^{(\rho-1)}(0) + \alpha \epsilon u_0$.

Proof: Substituting the first equation of (1) into (6), we have

$$\epsilon \dot{u} = -\alpha \left(\xi_e^{(\rho)} + a_r^T x_r - b_r r + a_e^T e \right).$$

Substituting for $\xi_r^{(\rho)}$ from (2) into the preceding yields

$$\epsilon \dot{u} = -\alpha \left(\xi_e^{(\rho)} - \xi_r^{(\rho)} + a_e^T e \right) = -\alpha \left(\xi_e^{(\rho)} + a_e^T e \right).$$

Taking the time integral and dividing by $\epsilon (> 0)$ on both sides, we get (8) with \tilde{u}_0 being the constant of integration. Finally, enforcing $u(0) = u_0$ in (6) yields $\tilde{u}_0 = \xi_e^{(\rho-1)}(0) + \alpha \epsilon u_0$. ■

Observing that $\xi_e^{(\rho-1)} = [0, \dots, 0, 1]e$, it can be seen that (8) is a *full state feedback* PI controller acting on the tracking error and its time derivatives and integrals (see also Fig. 2). Furthermore, observe that when expressed in the error coordinates e , the PI controller is not explicitly dependent on the reference model dynamics. Hence the (exogenous) reference model (2) can be replaced by any stable signal generator. Alternatively, if r is $\rho+1$ times continuously differentiable with $r^{(\rho+1)}$ bounded, and all its time derivatives up to $r^{(\rho)}$ are available for feedback, they can be used directly without a need for any signal generator.

The significance of this result is threefold:

- 1) The PI controller allows a very simple *exact* realization of the ADI control law. Furthermore, no feedback of z is required.
- 2) The PI controller is a *linear* realization of a (in general) nonlinear control law.
- 3) The PI controller realization is independent of the nonlinear function $f(x, z, u)$ in (1), except for the sign of the control effectiveness, $\text{sgn}(\frac{\partial f}{\partial u})$.

Remark 1: Any *nonaffine-in-control* system whose state evolution is described by ordinary differential equations of the form $\dot{x} = f(x, u)$ can be transformed into an *affine-in-control* nonlinear system by defining the *extended system* [17]

$$\dot{x} = f(x, v), \quad \dot{v} = u,$$

with input u and auxiliary state v . Therefore, any results for affine-in-control systems like [2] can be applied to this extended system. However, this approach has some disadvantages as outlined in [18]. In particular, if the PI controller of [2] is designed for the extended system, the resultant PI controller will be of a higher order than the one presented herein. Furthermore, since (1) and (6) can be rewritten in the form

$$\begin{aligned} \xi^{(\rho)} &= f(x, z, v), \\ \dot{z} &= g(x, z, v), \\ \dot{v} &= -\frac{\alpha}{\epsilon} \hat{f}(t, x, z, v), \end{aligned}$$

where v is the auxiliary state, and

$$\hat{f}(t, x, z, v) = f(x, z, v) + a_r^T x_r(t) - b_r r(t) + a_e^T (x - x_r(t)),$$

it can be seen that the ADI controller (6) can be interpreted as a (high-gain) state feedback controller on the *extended system*. However, using the ADI controller for the original system avoids the undesirable high-gain control effects.

Remark 2: A similar result is presented in [3], where it was shown that the constructed PI controller for a *relative degree one*, minimum-phase *affine-in-control* nonlinear system is an *approximate realization* of an *exact feedback linearizing controller* [10].

Here, we have shown by equivalence to the ADI controller [6], that for SISO minimum-phase nonaffine-in-control systems of the form (1), a stabilizing tracking PI controller exists. The extension to a (restrictive) class of MIMO minimum-phase nonaffine-in-control systems is straightforward [4], [5]. However, for the ADI controller of [16], it is not known whether such PI realizations will exist in general.

III. NONEQUIVALENCE IN PERTURBED SYSTEMS

Consider the scenario where the ADI controller is designed for a nominal system, but applied to a perturbed system. It is clear that when the ADI controller and its induced PI controller are applied to the *exact* system (1), they will produce identical time responses for the same excitation and *compatible* initial conditions. As will be shown in Section IV, even when restricted to *unperturbed* minimum-phase LTI systems, this equivalence holds only for the time response

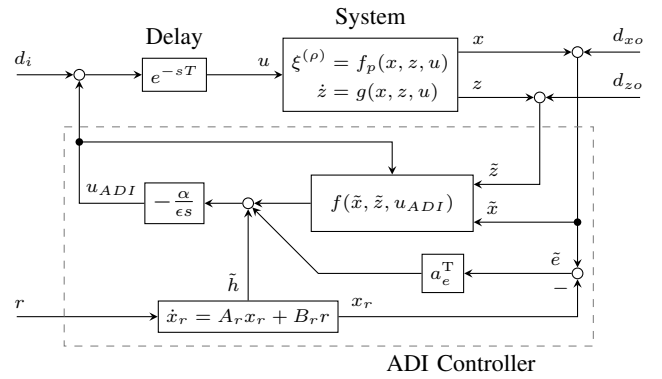

Fig. 1. Block diagram of perturbed open loop system driven by ADI controller.

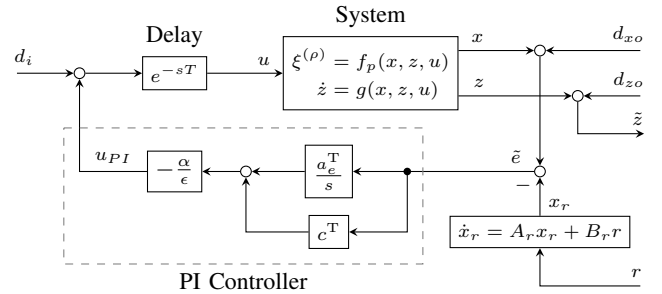

Fig. 2. Block diagram of perturbed open loop system driven by induced PI controller.

and not, in particular, to robustness properties. Equivalence in the time response also does not hold when these controllers are applied to a perturbed system. In particular, we show in this section that the equivalence between the ADI controller and its induced PI controller is lost when the system is subjected to

- 1) noise/disturbances at plant input/output,
- 2) perturbations of nonlinear function $f(x, z, u)$ in (1), or
- 3) time delays at plant input/output.

The same conclusions hold for the MIMO case.

Let the relations between the input/output noise/disturbances and the open loop system (1) be defined by

$$u(t) = u_c(t - T) + d_i(t - T), \quad \tilde{x} = x + d_{x0}, \quad \tilde{z} = z + d_{z0}, \quad (9)$$

where $T \geq 0$ is the delay interval, u_c, d_i are the commanded input and input noise/disturbance respectively, \tilde{x}, \tilde{z} are the measurements, and d_{x0}, d_{z0} are output noise/disturbances acting on x, z respectively. Let $\dot{x}_r = A_r x_r + B_r r$, $[\tilde{h}, x_r^T]^T = C_r x_r + D_r r$, be a state space realization of the reference model (2), where $\tilde{h}(t) = a_r^T x_r(t) - b_r r(t)$. Additionally, define the selector vector

$$c = [0, \dots, 0, 1]^T \in \mathbb{R}^\rho.$$

When the open loop system (1) is subjected to a time delay of T at the input, input/output noise/disturbances defined by (9), and perturbations of f to f_p , the block diagrams of the ADI ($u_c \equiv u_{ADI}$) and PI ($u_c \equiv u_{PI}$) controlled systems are shown in Fig. 1 and 2 respectively. Here, e^{-sT} represents the delay by T seconds operator and $\frac{1}{s}$ represents the time integral operator.

A. Disturbances at Plant Input/Output

Consider the system defined by (1) and (9) with $T = 0$. Define signal h as

$$h = a_r^T x_r - b_r r + a_e^T (e + d_{x0}).$$

The ADI controller applied to this system is then

$$\epsilon \dot{u}_{ADI} = -\alpha(f(x + d_{x_o}, z + d_{z_o}, u_{ADI}) + h).$$

The PI controller applied to the same system is

$$u_{PI}(t) = -\frac{\alpha}{\epsilon} \left(\xi_e^{(\rho-1)}(t) + c^T d_{x_o}(t) - \tilde{u}_0 + a_e^T \int_0^t e(\gamma) + d_{x_o}(\gamma) d\gamma \right),$$

which, assuming that $d_{x_o}(t)$ is differentiable, can be shown to be equivalent to

$$\epsilon \dot{u}_{PI} = -\alpha(f(x, z, u_{PI} + d_i) + c^T \dot{d}_{x_o} + h).$$

Clearly, the ADI and PI controllers are equivalent (in general) only when d_i , d_{x_o} and d_{z_o} are identically zero.

Remark 3: Note that the above expressions for the ADI and PI controllers can be written in integral form without having to assume differentiability of $d_{x_o}(t)$.

B. Delay-free Perturbation of System

If the system to be controlled is defined by (1), but with $f(x, z, u)$ perturbed to $f_p(x, z, u)$, the ADI controller remains unaltered as (6), rewritten here with symbol u_{ADI} as

$$\epsilon \dot{u}_{ADI} = -\alpha(f(x, z, u_{ADI}) + a_r^T x_r - b_r r + a_e^T e).$$

In contrast, the PI controller can be shown to be equivalent to

$$\epsilon \dot{u}_{PI} = -\alpha(f_p(x, z, u_{PI}) + a_r^T x_r - b_r r + a_e^T e),$$

the difference being the nonlinear function $f_p(x, z, u_{PI})$. The independence of the PI controller from the nonlinear function $f(x, z, u)$ renders it relatively insensitive to such delay-free perturbations. It is clear that in the presence of such perturbations, Theorem 1 applies to the PI controller unaltered. This shows that for all delay-free perturbations described by $f_p(x, z, u)$ satisfying the hypotheses of Theorem 1 and such that $\text{sgn}(\frac{\partial f}{\partial u}) = \text{sgn}(\frac{\partial f_p}{\partial u})$, there exists a sufficiently small positive ϵ for which the PI controller stabilizes the system. The same do not hold for the ADI controller under such perturbations, as demonstrated by the following example.

Example 1: Consider the second order minimum-phase LTI system

$$\xi^{(2)} + a_1 \dot{\xi} + a_0 \xi = (1 + \delta)u,$$

where $\delta (> -1$ to ensure that $\text{sgn}(\frac{\partial f}{\partial u}) = +1$ is constant) is a small *unknown* constant perturbation, nominally 0. Let the ADI controller be designed for $\delta = 0$, with $a_e = [a_{e0}, a_{e1}]^T$, $a_{e0}, a_{e1} \in (0, \infty)$. It can be shown that the characteristic polynomial of the closed loop system is

$$p_{ADI}(s) = \epsilon s^3 + (1 + \epsilon a_1) s^2 + ((1 + \delta) a_{e1} + \epsilon a_0 - \delta a_1) s + ((1 + \delta) a_{e0} - \delta a_0).$$

Consider the case where a_{e0} and a_{e1} are fixed to satisfy some desired stable error dynamics, and the system coefficients satisfy $a_0 \ll -1 < 0$, $a_1 \gg a_{e1} > 0$. For example, this can represent an unstable first order system $\frac{1}{s-1}$ in series with a stable first order system with fast dynamics $\frac{1}{s+a}$, where $a \gg 1$. Then for stability, we require at least

$$-\left| \frac{a_{e0}}{a_0 - a_{e0}} \right| < \delta < \left| \frac{a_{e1} + \epsilon a_0}{a_1 - a_{e1}} \right|.$$

For sufficiently large $a_0 \ll -1$ and $a_1 \gg 1$, a small deviation of δ from zero in either direction induces instability regardless of the choice of ϵ .

It can be shown that the characteristic polynomial of the closed loop system controlled by the induced PI controller is

$$p_{PI}(s) = \epsilon s^3 + (1 + \delta + \epsilon a_1) s^2 + ((1 + \delta) a_{e1} + \epsilon a_0) s + (1 + \delta) a_{e0},$$

so that when ϵ is small enough, a_{e0} and a_{e1} dominates the coefficients of the characteristic polynomial.

Remark 4: Theorem 1 states that for a fixed a_e , there is a sufficiently small ϵ to obtain a stabilizing ADI design. Example 1 only illustrates that Theorem 1 does not apply to the ADI controller under perturbations of $f(x, z, u)$. It does not imply that a stabilizing ADI controller does not exist, but only that ϵ cannot be independent of a_e under such perturbations. Observe also that when $\delta \leq -1$, the key assumption that $\text{sgn}(\frac{\partial f}{\partial u})$ is a constant is violated, so that in this case, the PI controller also fails to stabilize the system.

C. A Single Time Delay at Plant Input/Output

Here, we consider the case where there is a *single* delay present at the plant input/output. Since by definition, time-invariant systems commute with the delay operator [13, Definition 5.2.2, pp. 150], and system (1) is indeed time-invariant [13, pp. 150] [19, Proposition 1], it suffices to consider the case where the *single* delay appears at the input, as illustrated in Fig. 1 and 2, with $f_p = f$, $d_i \equiv 0$, $d_{x_o} \equiv 0$, and $d_{z_o} \equiv 0$. To emphasize the presence of the delay in the subsequent expressions, we refer this input delay to the output (permissible due to commutativity of time-invariant systems and the delay operator), so that in place of (9), we have

$$u(t) = u_c(t), \quad \tilde{x}(t) = x(t - T), \quad \tilde{z}(t) = z(t - T). \quad (10)$$

The system to be controlled is therefore defined by (1) and (10). With

$$h(t) = a_r^T x_r(t) - b_r r(t) + a_e^T (x(t - T) - x_r(t)),$$

the ADI controller takes the form (see Fig. 1 for illustration of how u_{ADI} enters f)

$$\epsilon \dot{u}_{ADI}(t) = -\alpha(f(x(t - T), z(t - T), u_{ADI}(t)) + h(t)).$$

In contrast, the PI controller can be shown to be equivalent to

$$\begin{aligned} \epsilon \dot{u}_{PI}(t) &= -\alpha(c^T \tilde{x}(t) - \xi_r^{(\rho)}(t) + a_e^T (\tilde{x}(t) - x_r(t))), \\ &= -\alpha(\xi^{(\rho)}(t - T) + a_r^T x_r(t) - b_r r(t) \\ &\quad + a_e^T (x(t - T) - x_r(t))), \\ &= -\alpha(f(x(t - T), z(t - T), u_{PI}(t - T)) + h(t)), \end{aligned}$$

the difference being that $u_{PI}(t)$ enters the nonlinear function f delayed by T .

Remark 5: The above only shows that the ADI and PI solutions differ when a single delay is introduced at the plant input/output, without regard for the stability of the delayed closed-loop system. Work is underway to study closed-loop stability and tracking performance for systems with time delays.

IV. LINEAR TIME-INVARIANT SYSTEMS

Here, we use well established linear system techniques to compare some robustness properties of the closed loop system controlled by the ADI controller and its induced PI equivalent when the system is minimum-phase and LTI.

Consider the class of ρ -th order SISO minimum-phase LTI systems described by

$$\xi^{(\rho)} + a_{\rho-1} \xi^{(\rho-1)} + \dots + a_1 \dot{\xi} + a_0 \xi = bu, \quad (11)$$

where b is a constant scalar satisfying $|b| \geq b_0 > 0$, $x = [\xi, \dot{\xi}, \dots, \xi^{(\rho-1)}]^T$ and u are the system state and control input

respectively. The PI controller (8) applied to system (11) can be written as

$$u_{PI}(t) = -\frac{\text{sgn}(b)}{\epsilon} \left(\xi^{(\rho-1)}(t) - \xi_r^{(\rho-1)}(t) + a_e^T \int_0^t x(\gamma) - x_r(\gamma) d\gamma - \tilde{u}_0 \right), \quad (12)$$

where ξ_r and x_r are defined in (2). The transfer functions of (11) and (12) are then

$$x(s) = \frac{b}{s^\rho + a_{\rho-1}s^{\rho-1} + \dots + a_1s + a_0} [1, s, \dots, s^{\rho-1}]^T u(s),$$

$$u_{PI}(s) = -\frac{\text{sgn}(b)}{\epsilon s} [s^\rho + a_{e0}, a_{e1}, \dots, a_{e(\rho-1)}] (x(s) - x_r(s)),$$

respectively. Breaking the loop at the *input* to the system, the *input* loop transfer function is then

$$L_{PI}(s) = \frac{|b| s^\rho + a_{e(\rho-1)}s^{\rho-1} + \dots + a_{e1}s + a_{e0}}{\epsilon s s^\rho + a_{\rho-1}s^{\rho-1} + \dots + a_1s + a_0}. \quad (13)$$

The ADI controller (6) applied to the same system is

$$\epsilon \dot{u}_{ADI} = -\text{sgn}(b) \left((a_e^T - a^T)x + bu + (a_r^T - a_e^T)x_r - b_r r \right),$$

where $a = [a_0, a_1, \dots, a_{\rho-1}]^T$. Its transfer function and *input* loop transfer function are then

$$u_{ADI}(s) = -\frac{\text{sgn}(b)}{\epsilon s + |b|} \left((a_e^T - a^T)x(s) + (a_r^T - a_e^T)x_r(s) - b_r r(s) \right),$$

$$L_{ADI}(s) = \frac{|b|}{\epsilon s + |b|} \frac{(a_e^T - a^T)[1, s, \dots, s^{\rho-1}]^T}{s^\rho + a_{\rho-1}s^{\rho-1} + \dots + a_1s + a_0}, \quad (14)$$

respectively. The corresponding *input* sensitivity functions are

$$S_{PI}(s) = (1 + L_{PI}(s))^{-1}, \quad S_{ADI}(s) = (1 + L_{ADI}(s))^{-1}.$$

A. Input Sensitivity Function

First, we show that the \mathcal{H}_∞ norm of the *input* sensitivity function of the closed-loop system controlled by the induced PI controller (8) is strictly less than the \mathcal{H}_∞ norm of the input sensitivity function of the system controlled by the ADI controller (6). For the following result, recall the role of ϵ^* in Theorem 1, which is the upper bound of ϵ in (6) to obtain a stabilizing ADI controller.

Proposition 1: For any $\epsilon \in (0, \infty)$,

$$S_{PI}(s) = \frac{\epsilon s}{\epsilon s + |b|} S_{ADI}(s). \quad (15)$$

For any $\epsilon \in (0, \epsilon^*)$, where ϵ^* is defined in Theorem 1,

$$\|S_{PI}(s)\|_\infty < \|S_{ADI}(s)\|_\infty. \quad (16)$$

Proof: For ease of polynomial manipulations, define $\tilde{s} = [1, s, \dots, s^{\rho-1}]^T$. Then from (13) and (14), we have

$$L_{PI}(s) = \frac{|b| (s^\rho + a_e^T \tilde{s})}{\epsilon s (s^\rho + a^T \tilde{s})}, \quad L_{ADI}(s) = \frac{|b| (a_e^T - a^T) \tilde{s}}{(\epsilon s + |b|) (s^\rho + a^T \tilde{s})},$$

which gives

$$1 + L_{PI}(s) = \frac{\epsilon s^{\rho+1} + |b|s^\rho + (\epsilon s a^T + |b|a_e^T) \tilde{s}}{\epsilon s (s^\rho + a^T \tilde{s})}.$$

From above, we have

$$1 + L_{ADI}(s) = \frac{\epsilon s^{\rho+1} + |b|s^\rho + (\epsilon s a^T + |b|a_e^T) \tilde{s}}{(\epsilon s + |b|) (s^\rho + a^T \tilde{s})},$$

$$= \frac{\epsilon s}{\epsilon s + |b|} (1 + L_{PI}(s)),$$

which proves (15) for all $\epsilon \in (0, \infty)$.

Next, observe from Theorem 1 that any choice of $\epsilon \in (0, \epsilon^*)$ results in a stable closed loop system. Then $\|S_{PI}(s)\|_\infty$ and $\|S_{ADI}(s)\|_\infty$ are both finite. Let $|S_{PI}(j\omega)|$ attain its maximum at ω_0 , so that $\|S_{PI}(s)\|_\infty = |S_{PI}(j\omega_0)|$. From (15), at frequency ω_0 , we have

$$|S_{ADI}(j\omega_0)| = \left| 1 - j \frac{|b|}{\epsilon \omega_0} \right| |S_{PI}(j\omega_0)| > \|S_{PI}(s)\|_\infty.$$

Since $\|S_{ADI}(s)\|_\infty \geq |S_{ADI}(j\omega_0)|$, the second conclusion (16) follows. ■

Observe that the \mathcal{H}_∞ norm of the sensitivity function is one measure of robustness, the reciprocal of which is the shortest Euclidean distance in the complex plane of the Nyquist plot from the critical point $-1 + j0$. From (16), we see that the shortest distance between the Nyquist plot of $L_{PI}(s)$ and the critical point is always larger than that of $L_{ADI}(s)$, which imply that the PI controlled system can tolerate larger gain and/or phase perturbations to $L_{PI}(s)$ while maintaining stability compared to the ADI controlled system. Clearly, in terms of the input sensitivity function, the PI controller has better robustness properties.

B. Time Delay Margin

Here, we show that as $\epsilon \rightarrow 0$, the time delay margin of the PI controlled system, $DM_{PI}(\epsilon)$, approaches zero, while for the ADI controlled system, the time delay margin is finite and bounded away from zero. The main disadvantage of the PI controlled system is that as $\epsilon \rightarrow 0$, the gain crossover frequency of its open loop transfer function approaches infinity, so that even with finite positive phase margin, its time delay margin vanish in the limit.

For a *stable* LTI system with loop transfer function $L(s)$, we use the definition of the time delay margin [20]

$$DM = \inf \{ \theta_m / \omega_c \in [0, \infty) \mid \exists \omega_c \in (0, \infty), |L(j\omega_c)| = 1, \theta_m = (\angle L(j\omega_c) \bmod 2\pi) - \pi \},$$

where θ_m and ω_c are the phase margin and gain crossover frequency of $L(s)$ respectively, with the usual convention that the infimum of an empty set is $+\infty$. It is a measure of the amount of time delay that an LTI system can tolerate, beyond which the closed loop system destabilizes, and is another measure of system robustness of practical importance.

Proposition 2: The time delay margin of the closed loop system stabilized by the PI controller (8) satisfy

$$\lim_{\epsilon \rightarrow 0} DM_{PI}(\epsilon) = 0.$$

Proof: Since the closed loop system is stable by assumption, the phase margin satisfy $\theta_m \in [0, \pi)$ if there exists at least one *real* ω_c such that $|L_{PI}(j\omega_c)| = 1$, ie., that there is at least one gain crossover point. Hence it is sufficient to show that as $\epsilon \rightarrow 0$, there exists a solution $\omega_c \in (0, \infty)$ satisfying $|L_{PI}(j\omega_c)| = 1$ such that $\omega_c \rightarrow \infty$.

From (13), it can be seen that $L_{PI}(s)$ is strictly proper and has a pole at $s = 0$. Therefore, we have

$$\lim_{\omega \rightarrow \infty} |L_{PI}(j\omega)| = 0, \quad \lim_{\omega \rightarrow 0} |L_{PI}(j\omega)| = \infty.$$

By the continuity of $|L_{PI}(j\omega)|$ with ω , there must exist a *real* $\omega_c(\epsilon) \in (0, \infty)$ (depending on ϵ) that satisfy

$$|L_{PI}(j\omega_c(\epsilon))| = \frac{|b|}{\epsilon \omega_c(\epsilon)} \frac{|p(j\omega_c(\epsilon))|}{|q(j\omega_c(\epsilon))|} = 1, \quad \forall \epsilon \in [0, \infty),$$

where $p(s) = s^\rho + a_{e(\rho-1)}s^{\rho-1} + \dots + a_{e1}s + a_{e0}$ and $q(s) = s^\rho + a_{\rho-1}s^{\rho-1} + \dots + a_1s + a_0$. Rearranging terms and taking limits yields

$$\lim_{\epsilon \rightarrow 0} \omega_c(\epsilon) = \lim_{\epsilon \rightarrow 0} \frac{|b|}{\epsilon} \frac{|p(j\omega_c(\epsilon))|}{|q(j\omega_c(\epsilon))|}. \quad (17)$$

Since $p(s)$ is the characteristic polynomial of the stable desired error dynamics (3), all roots of $p(s) = 0$ have negative real parts, so that none lies on the $j\omega$ axis and for all $\omega \in \mathbb{R}$, $|p(j\omega)| \neq 0$. Hence $|p(j\omega_c(\epsilon))| \neq 0$ for all $\epsilon \in [0, \infty)$. Since $p(s)$ and $q(s)$ are of the same order, we have $\frac{|q(j\omega_c(\epsilon))|}{|p(j\omega_c(\epsilon))|} < \infty$ for all $\epsilon \in [0, \infty)$. Then from (17), we have the desired conclusion $\lim_{\epsilon \rightarrow 0} \omega_c(\epsilon) = \infty$. ■

This shows that there is a practical lower bound of ϵ when implementing the equivalent PI controller. The following shows a key advantage of the ADI controller as $\epsilon \rightarrow 0$.

Proposition 3: There exists a $\tau > 0$ such that the time delay margin of the closed loop system stabilized by the ADI controller (6) satisfy

$$\lim_{\epsilon \rightarrow 0} DM_{ADI}(\epsilon) \geq \tau > 0. \quad (18)$$

Proof: From (14), we have

$$\tilde{L}_{ADI}(s) := \lim_{\epsilon \rightarrow 0} L_{ADI}(s) = \frac{(a_e^T - a^T)[1, s, \dots, s^{\rho-1}]^T}{s^\rho + a^T[1, s, \dots, s^{\rho-1}]^T},$$

which determines $\lim_{\epsilon \rightarrow 0} DM_{ADI}(\epsilon)$. Observe that (18) will not hold only if there is a gain crossover point of $\tilde{L}_{ADI}(s)$ for which the phase margin satisfies $\theta_m = 0$, or for which the gain crossover frequency satisfies $\omega_c \rightarrow \infty$. When the phase margin is zero, we have $\tilde{L}_{ADI}(s) = -1$, giving

$$s^\rho + a_e^T[1, s, \dots, s^{\rho-1}]^T = 0, \quad (19)$$

for $s = j\omega_c$, $\omega_c \in \mathbb{R}$. Since this is the characteristic equation of the chosen stable error dynamics, no roots of (19) can lie on the $j\omega$ axis so that the phase margin cannot be zero. Finally, since $\tilde{L}_{ADI}(s)$ is strictly proper, all gain crossover frequencies ω_c satisfying $|\tilde{L}_{ADI}(j\omega_c)| = 1$ must be finite. ■

Clearly, the ADI controller has better tolerance of time delays as $\epsilon \rightarrow 0$, which is necessary to achieve a good approximation of the exact dynamic inversion solution.

C. Comment on Similarity Transformations for LTI Systems

The results above show that not all transformations of a system/controller to an equivalent realization that preserves its time response do indeed preserve its closed-loop robustness properties. However, it can be easily shown that the familiar similarity transformations well-known for LTI systems indeed preserve the system's transfer function, and hence its frequency domain closed-loop robustness properties. In the equivalence transformation between the ADI and PI controllers, their transfer functions differ, which is the cause of the disparities.

V. CONCLUSIONS

Through equivalence with the approximate dynamic inversion (ADI) method, it was shown that a stabilizing tracking PI controller exists for minimum-phase nonaffine-in-control systems. This complements existing results on PI control of nonlinear systems, and shows that the class of SISO nonlinear systems for which stabilizing PI controllers have yet to be found (if they exist), is the class of *nonminimum-phase* nonlinear systems that are not exponentially stable.

The equivalence between the ADI and induced PI controller holds only for the time response when applied to the *unperturbed* system. Even when restricted to minimum-phase *unperturbed* LTI systems, they differ in key robustness properties. The choice between implementing the ADI controller or its induced PI equivalent lies in whether a sufficiently accurate model of the system is available, or whether time delays are the major limitations in the system. When knowledge of the system is poor, the PI controller would be preferred.

When time delays are dominant, the ADI controller is preferable. It would be interesting to see if these two equivalent controllers can be combined in some ways to obtain a design that achieves the strengths of each, or allows the trading off of one aspect for another.

These results show that in general, for controllers/systems that are equivalent in some sense, properties that do not define the equivalence relation cannot be assumed to hold under such equivalence transformations. In particular, controllers achieving the same time response cannot be assumed to achieve the same closed loop robustness properties.

REFERENCES

- [1] C. A. Desoer and C.-A. Lin, "Tracking and disturbance rejection of MIMO nonlinear systems with PI controller," *IEEE Trans. Autom. Control*, vol. 30, no. 9, pp. 861 – 867, Sep. 1985.
- [2] H. K. Khalil, "Universal integral controllers for minimum-phase nonlinear systems," *IEEE Trans. Autom. Control*, vol. 45, no. 3, pp. 490 – 494, Mar. 2000.
- [3] J. Alvarez-Ramirez, G. Fernandez, and R. Suarez, "A PI controller configuration for robust control of a class of nonlinear systems," *J. Frankl. Inst.-Eng. Appl. Math.*, vol. 339, no. 1, pp. 29 – 41, Jan. 2002.
- [4] J. Teo and J. P. How, "Equivalence between approximate dynamic inversion and proportional-integral control," MIT, Cambridge, MA, Tech. Rep. ACL08-01, Sep. 2008, Aerosp. Controls Lab. [Online]. Available: <http://hdl.handle.net/1721.1/42839>
- [5] —, "On approximate dynamic inversion," MIT, Cambridge, MA, Tech. Rep. ACL09-01, May 2009, Aerosp. Controls Lab. [Online]. Available: <http://hdl.handle.net/1721.1/45514>
- [6] N. Hovakimyan, E. Lavretsky, and A. Sasane, "Dynamic inversion for nonaffine-in-control systems via time-scale separation. part I," *J. Dyn. Control Syst.*, vol. 13, no. 4, pp. 451 – 465, Oct. 2007.
- [7] J. D. Moringred, B. E. Paden, D. E. Seborg, and D. A. Mellichamp, "An adaptive nonlinear predictive controller," in *Proc. American Control Conf.*, San Diego, CA, May 1990, pp. 1614 – 1619.
- [8] N. C. Sahoo, J. X. Xu, and S. K. Panda, "An iterative learning-based modulation scheme for torque control in switched reluctance motors," *Electr. Mach. Power Syst.*, vol. 28, no. 11, pp. 995 – 1018, Nov. 2000.
- [9] J. D. Bošković, L. Chen, and R. K. Mehra, "Multivariable adaptive controller design for a class of non-affine models arising in flight control," in *Proc. 40th IEEE Conf. Decision and Control*, vol. 3, Orlando, FL, Dec. 2001, pp. 2442 – 2447.
- [10] S. Devasia, D. Chen, and B. Paden, "Nonlinear inversion-based output tracking," *IEEE Trans. Autom. Control*, vol. 41, no. 7, pp. 930 – 942, Jul. 1996.
- [11] H. K. Khalil, *Nonlinear Systems*, 3rd ed. Upper Saddle River, NJ: Prentice Hall, 2002.
- [12] P. V. Kokotovic and R. Marino, "On vanishing stability regions in nonlinear systems with high-gain feedback," *IEEE Trans. Autom. Control*, vol. 31, no. 10, pp. 967 – 970, Oct. 1986.
- [13] F. M. Callier and C. A. Desoer, *Linear System Theory*, ser. Springer Texts Electr. Eng. New York, NY: Springer, 1991.
- [14] E. A. Lyashenko and L. B. Ryashko, "Optimal controllers not satisfying the separation theorem," *Cybern. Syst. Anal.*, vol. 36, no. 3, pp. 426 – 436, May 2000.
- [15] M. Verwoerd, G. Meinsma, and T. de Vries, "On admissible pairs and equivalent feedback - Youla parameterization in iterative learning control," *Automatica*, vol. 42, no. 12, pp. 2079 – 2089, Dec. 2006.
- [16] N. Hovakimyan, E. Lavretsky, and C. Cao, "Dynamic inversion for multivariable non-affine-in-control systems via time-scale separation," *Int. J. Control*, vol. 81, no. 12, pp. 1960 – 1967, Dec. 2008.
- [17] A. J. van der Schaft, "Observability and controllability for smooth nonlinear systems," *SIAM J. Control Optim.*, vol. 20, no. 3, pp. 328 – 337, May 1982.
- [18] C. I. Byrnes and X. Hu, "The zero dynamics algorithm for general nonlinear systems and its application in exact output tracking," *J. Math. Syst. Estim. Control*, vol. 3, no. 1, pp. 51 – 72, 1993.
- [19] J. Teo, J. P. How, and E. Lavretsky, "On approximate dynamic inversion and proportional-integral control," in *Proc. American Control Conf.*, St. Louis, MO, Jun. 2009, pp. 1592 – 1597.
- [20] R. H. Middleton and D. E. Miller, "On the achievable delay margin using LTI control for unstable plants," *IEEE Trans. Autom. Control*, vol. 52, no. 7, pp. 1194 – 1207, Jul. 2007.